

ST-3714, ST-3734 (Only used the DeviceNet network Adapter NA-9112, NA-9212)

RTD, 4 Channels, TEMP. Controller, RTD Input, SSR Output (ST-3714)
 RTD, 4 Channels, TEMP. Controller, RTD Input, Current Output (ST-3734)

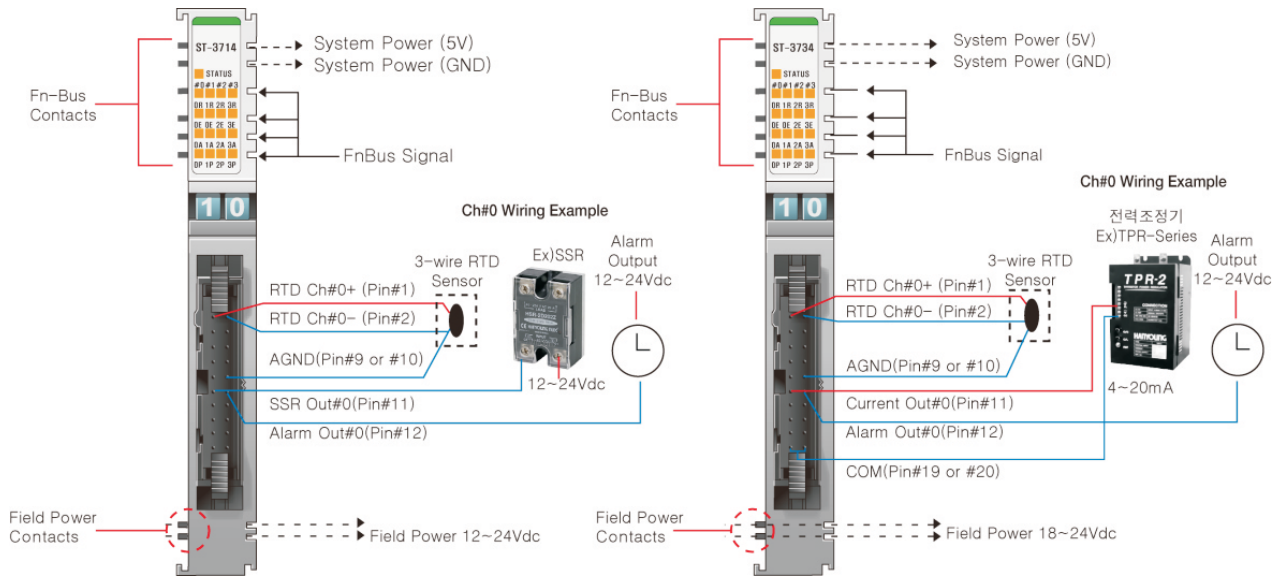

FnIO S-Series Analog Input

Item	ST-3714	ST-3734																																																																																								
Input Specification	4 Channels																																																																																									
Number of Inputs	4 Channels																																																																																									
Indicators	1 Green/Red Fn-Bus state 4 Green LEDs/ch - Ready (R) - Sensor Error (E) - Alarm Output (A) - Process Output for SSR (P)	1 Green/Red Fn-Bus state 4 Green LEDs/ch - Ready (R) - Sensor Error (E) - Alarm Output (A) - Process Output (P)																																																																																								
Sensor Types	- RTD Input/ch, - PT100, PT50 - JPT100, - CU20, - TBD																																																																																									
Control Method	P, PI, PD, PID with Auto tuning (Limit Cycle Method), On/Off (PB=0)																																																																																									
Control Output	1 DC-Sink PWM Output for SSR control (11~28.8Vdc) 1 DC-Sink Alarm Output (11~28.8Vdc)	1 Current Output (4~20mA, 12bit Resolution) 1 DC-Sink Alarm Output (18~28.8Vdc)																																																																																								
Excitation Current for RTD	1mA																																																																																									
Parameter Setting	NA-9112(DeviceNet), NA-9715(DeviceNet, Serial), NA-9785(Ethernet, Serial), TBD																																																																																									
Proportional Band (PB)	0.0~1000.0℃																																																																																									
Integral Time (Ti)	0~3600sec																																																																																									
Derivative Time (Td)	0~3600sec																																																																																									
Control Cycle (Tc)	0.5sec fixed																																																																																									
Sample Time (Ts)	0.5sec fixed																																																																																									
Module Accuracy	± 0.1℃ FS@25℃ or 1℃, TBD																																																																																									
Etc Functions	ARW, MR, Temp. Offset, Hysteresis (On/Off) TBD																																																																																									
General Specification																																																																																										
Power Dissipation	Max. 200mA@5.0Vdc, TBD																																																																																									
Isolation	I/O to Control Logic : Photocoupler Isolation DC Module (Included Analog Module) : Terminal Block to F.G 500Vac/1min																																																																																									
Field power	Supply Voltage : 24Vdc Nominal / Voltage Range : 11~28.8Vdc Supply Voltage : 24Vdc Nominal / Voltage Range : 18~28.8Vdc																																																																																									
Wiring	I/O Cable up to AWG22 / Unit Connector : HIF3BA-20PA-2.54DSA Mate Connector : HIF3C-20D-2.54C, HIF3BA-20D-2.54C / Mate Crimp Pin : HIF3C-2226SCA																																																																																									
Weight	100g, TBD																																																																																									
Module Size	12mm x 99mm x 70mm																																																																																									
Environment Condition	Refer to "Environment Specification"(page : 1-191)																																																																																									
	<table border="1"> <thead> <tr> <th>Pin No.</th> <th>Description</th> <th>Pin No.</th> <th>Description</th> <th>Pin No.</th> <th>Description</th> <th>Pin No.</th> <th>Description</th> </tr> </thead> <tbody> <tr> <td>1</td> <td>RTD Ch#0+</td> <td>2</td> <td>RTD Ch#0-</td> <td>1</td> <td>RTD Ch#0+</td> <td>2</td> <td>RTD Ch#0-</td> </tr> <tr> <td>3</td> <td>RTD Ch#1+</td> <td>4</td> <td>RTD Ch#1-</td> <td>3</td> <td>RTD Ch#1+</td> <td>4</td> <td>RTD Ch#1-</td> </tr> <tr> <td>5</td> <td>RTD Ch#2+</td> <td>6</td> <td>RTD Ch#2-</td> <td>5</td> <td>RTD Ch#2+</td> <td>6</td> <td>RTD Ch#2-</td> </tr> <tr> <td>7</td> <td>RTD Ch#3+</td> <td>8</td> <td>RTD Ch#3-</td> <td>7</td> <td>RTD Ch#3+</td> <td>8</td> <td>RTD Ch#3-</td> </tr> <tr> <td>9</td> <td>AGND</td> <td>10</td> <td>AGND</td> <td>9</td> <td>AGND</td> <td>10</td> <td>AGND</td> </tr> <tr> <td>11</td> <td>SSR Out Ch#0</td> <td>12</td> <td>Alarm Out Ch#0</td> <td>11</td> <td>Current Out Ch#0</td> <td>12</td> <td>Alarm Out Ch#0</td> </tr> <tr> <td>13</td> <td>SSR Out Ch#1</td> <td>14</td> <td>Alarm Out Ch#1</td> <td>13</td> <td>Current Out Ch#1</td> <td>14</td> <td>Alarm Out Ch#1</td> </tr> <tr> <td>15</td> <td>SSR Out Ch#2</td> <td>16</td> <td>Alarm Out Ch#2</td> <td>15</td> <td>Current Out Ch#2</td> <td>16</td> <td>Alarm Out Ch#2</td> </tr> <tr> <td>17</td> <td>SSR Out Ch#3</td> <td>18</td> <td>Alarm Out Ch#3</td> <td>17</td> <td>Current Out Ch#3</td> <td>18</td> <td>Alarm Out Ch#3</td> </tr> <tr> <td>19</td> <td>AGND</td> <td>20</td> <td>AGND</td> <td>19</td> <td>COM</td> <td>20</td> <td>COM</td> </tr> </tbody> </table>	Pin No.	Description	Pin No.	Description	Pin No.	Description	Pin No.	Description	1	RTD Ch#0+	2	RTD Ch#0-	1	RTD Ch#0+	2	RTD Ch#0-	3	RTD Ch#1+	4	RTD Ch#1-	3	RTD Ch#1+	4	RTD Ch#1-	5	RTD Ch#2+	6	RTD Ch#2-	5	RTD Ch#2+	6	RTD Ch#2-	7	RTD Ch#3+	8	RTD Ch#3-	7	RTD Ch#3+	8	RTD Ch#3-	9	AGND	10	AGND	9	AGND	10	AGND	11	SSR Out Ch#0	12	Alarm Out Ch#0	11	Current Out Ch#0	12	Alarm Out Ch#0	13	SSR Out Ch#1	14	Alarm Out Ch#1	13	Current Out Ch#1	14	Alarm Out Ch#1	15	SSR Out Ch#2	16	Alarm Out Ch#2	15	Current Out Ch#2	16	Alarm Out Ch#2	17	SSR Out Ch#3	18	Alarm Out Ch#3	17	Current Out Ch#3	18	Alarm Out Ch#3	19	AGND	20	AGND	19	COM	20	COM	
Pin No.	Description	Pin No.	Description	Pin No.	Description	Pin No.	Description																																																																																			
1	RTD Ch#0+	2	RTD Ch#0-	1	RTD Ch#0+	2	RTD Ch#0-																																																																																			
3	RTD Ch#1+	4	RTD Ch#1-	3	RTD Ch#1+	4	RTD Ch#1-																																																																																			
5	RTD Ch#2+	6	RTD Ch#2-	5	RTD Ch#2+	6	RTD Ch#2-																																																																																			
7	RTD Ch#3+	8	RTD Ch#3-	7	RTD Ch#3+	8	RTD Ch#3-																																																																																			
9	AGND	10	AGND	9	AGND	10	AGND																																																																																			
11	SSR Out Ch#0	12	Alarm Out Ch#0	11	Current Out Ch#0	12	Alarm Out Ch#0																																																																																			
13	SSR Out Ch#1	14	Alarm Out Ch#1	13	Current Out Ch#1	14	Alarm Out Ch#1																																																																																			
15	SSR Out Ch#2	16	Alarm Out Ch#2	15	Current Out Ch#2	16	Alarm Out Ch#2																																																																																			
17	SSR Out Ch#3	18	Alarm Out Ch#3	17	Current Out Ch#3	18	Alarm Out Ch#3																																																																																			
19	AGND	20	AGND	19	COM	20	COM																																																																																			

* Alarm Output is Sink DC-Output (0.3A/1Output). / * COM is Field Power (0V) for Current Output and Alarm Output.